

LED Flat Panel Fixtures

(2 packs)

Even, consistent light.
Low maintenance.
High efficiency.

Features

- White finish
- DLC listed
- Maintenance free—no bulb to change
- Perfect, even light distribution
- Flicker-free driver
- CRI >80
- Ultra-slim edge-lit design
- Stamped and reinforced back plate
- Rated 50,000 hours
- 0-10V dimming
- Universal input voltage—100-277V, 50/60Hz
- 3500K, 4000K and 5000K versions
- Recessed, surface mount and suspension kits available*
- Certified for damp locations
- 5 year warranty

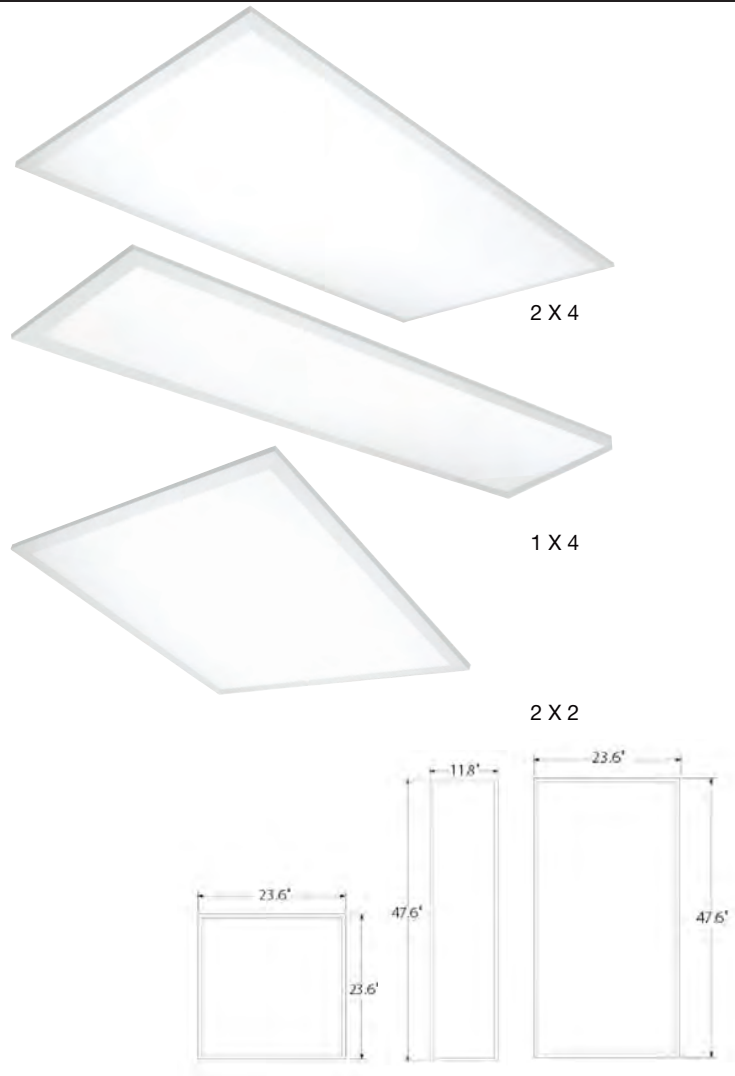

LED Flat Panel 2 Packs



Item Number	Lamp Description	W	Voltage	CRI	CCT	Lm	Life/Hrs.	Premium Available, > LM/W	Item#	Pack
2 Ft x 2 Ft. LED Flat Panel										
ML-321	2FT X 2FT LED FLAT PANEL 40 WATT	40	100-277	>80	3500K	4155	50K		ML-371	2
ML-322	2FT X 2FT LED FLAT PANEL 40 WATT	40	100-277	>80	4000K	4194	50K		ML-372	2
ML-323	2FT X 2FT LED FLAT PANEL 40 WATT	40	100-277	>80	5000K	4331	50K		ML-373	2
1 Ft x 4 Ft. LED Flat Panel										
ML-339	1FT X 4FT LED FLAT PANEL 40 WATT	40	100-277	80	3500K	4029	50K		ML-377	2
ML-340	1FT X 4FT LED FLAT PANEL 40 WATT	40	100-277	80	4000K	4098	50K		ML-378	2
ML-341	1FT X 4FT LED FLAT PANEL 40 WATT	40	100-277	80	5000K	4194	50K		ML-379	2
2 Ft x 4 Ft. LED Flat Panel										
ML-324	2FT X 4FT LED FLAT PANEL 50 WATT	50	100-277	>80	3500K	4906	50K		ML-374	2
ML-325	2FT X 4FT LED FLAT PANEL 50 WATT	50	100-277	>80	4000K	4968	50K		ML-375	2
ML-326	2FT X 4FT LED FLAT PANEL 50 WATT	50	100-277	>80	5000K	5139	50K		ML-376	2

